

# The *Electrical* **CONTACTOR**

THE OFFICIAL PUBLICATION OF THE FLORIDA  
ASSOCIATION OF ELECTRICAL CONTRACTORS

Volume 3 Number 1  
SPRING 2007



## **Insurance Bill Signed!**

*Provides Relief from Spiraling  
Increases in Windstorm Insurance*

**SEE YOU THERE!**  
FAEC 2007 Annual Spring  
Conference Omni Orlando  
Resort at ChampionsGate  
April 12-14, 2007

PRST STD  
U.S. POSTAGE  
**PAID**  
BENSALEM, PA  
PERMIT NO. 182

Plus { Mike Holt's Continuing Series  
on Grounding vs. Bonding



# **SESCO LIGHTING**

**"When Day Turns to Light"**

**"Service makes a difference, try us"**

# The *Electrical* CONTACTOR

FAEC STATE BOARD OF DIRECTORS - 2007

## 2007 Officers

### PRESIDENT

**MIKE CAUTHEN**  
DMC INDUSTRIES INC.  
P.O. Box 473, Sparr, FL 32192  
Phone: 352-620-9322  
Fax: 352-622-3953  
Email: [drladillo@aol.com](mailto:drladillo@aol.com)

### 1ST VICE PRESIDENT

**KEN CROSS**  
FERRAN SERVICES &  
CONTRACTING, INC.  
530 Grand Street, Orlando, FL 32805  
Phone: 407-422-3551  
Fax: 407-648-0961  
Email: [kcross@ferran-services.com](mailto:kcross@ferran-services.com)

### SECRETARY

**TIM QUIGLEY**  
TERRY ELECTRIC  
600 N. Thacker Ave., Suite A  
Kissimmee, FL 34741  
Phone: 407-572-2100  
Fax: 407-932-1135  
Email: [tiquigley@terryselectric.com](mailto:tiquigley@terryselectric.com)

### TREASURER

**ROY CAMPBELL**  
HYPOWER, INC.  
6100 Canal Road, #22  
Orlando, FL 32827  
Phone: 407-658-1515  
Fax: 407-658-1415  
Email: [rcampbell@hypowerinc.com](mailto:rcampbell@hypowerinc.com)

### PAST PRESIDENT

**HUSTON JOYNER, JR.**  
JOYNER ELECTRIC, INC.  
P.O. Box 20020, Tallahassee, FL 32316  
Phone: 850-576-1125  
Fax: 850-575-7889  
Email: [joynerelec@aol.com](mailto:joynerelec@aol.com)

### CENTRAL FLORIDA

**MIKE FREINER**  
BRIGHT FUTURE ELECTRIC, INC.  
630 Kissimmee Avenue, Ocoee, FL 34761  
Phone: 407-654-0155  
Fax: 407-654-1455  
Cell: 407-217-3488  
Email: [mikep@brifutelectric.com](mailto:mikep@brifutelectric.com)

### ORLANDO

**ROCKY SNEED**  
TRI-CITY ELECTRICAL CONTRACTORS  
430 West Drive  
Altamonte Springs, FL 32714  
Phone: 407-788-3500  
Fax: 407-682-1096  
Email: [rocky.sneed@tceelectric.com](mailto:rocky.sneed@tceelectric.com)

### JACKSONVILLE

**DAVID DEBERRY**  
DEBERRY ELECTRIC COMPANY, INC.  
P.O. Box 26037, Jacksonville, FL 32226  
Phone: 904-757-8424  
Fax: 904-757-7811  
Email: [david@deberryelectric.com](mailto:david@deberryelectric.com)

### JACKSONVILLE

**JEFF SANDERS**  
COASTAL ELECTRIC OF FLORIDA  
2759 St. Johns Bluff Road  
Jacksonville, FL 32246  
Phone: 904-645-0026  
Fax: 904-645-6186  
Email: [jtsceco@bellsouth.net](mailto:jtsceco@bellsouth.net)

### JACKSONVILLE

**KIM DEBERRY**  
KIM'S ELECTRIC  
P.O. Box 28792  
Jacksonville, FL 32218-8792  
Phone: 904-757-6633  
Fax: 904-757-5375  
Email: [kim.kimselectric@comcast.net](mailto:kim.kimselectric@comcast.net)

### OCALA

**BILL MANNING**  
M & M ELECTRIC SERVICE  
10876 SW 91st Avenue, Ocala, FL 34481  
Phone: 352-854-8338  
Fax: 352-854-4009  
Email: [mmelectricinc@yahoo.com](mailto:mmelectricinc@yahoo.com)

### BREVARD: NEED REPRESENTATIVE

### TAMPA: NEED REPRESENTATIVE

### ASSOCIATE DIRECTORS

### INSURANCE PARTNER

**CALEB REGER**  
FEDERATED MUTUAL INSURANCE  
P.O. Box 467500, Atlanta, GA 31146  
Phone: 404-497-8840  
Fax: 404-497-8845  
Email: [careger@fedins.com](mailto:careger@fedins.com)

### ASSOCIATE

**TIM MOORHEAD**  
WRIGHT, FULFORD, MOORHEAD,  
BROWN, P.A.  
P.O. Box 2828, Orlando, FL 32802  
Phone: 407-425-0234  
Fax: 407-425-0260  
Email: [tmoorehead@wfmblaw.com](mailto:tmoorehead@wfmblaw.com)

## TABLE OF CONTENTS

Executive Vice President Report.....	4
FAEC Membership Benefits .....	4
Legislative Report: Governor Crist Signs Comprehensive Insurance Bill .....	5
Grounding vs. Bonding Part 4 By Mike Holt .....	6
FAEC 2007 Annual Spring Conference Registration & Agenda .....	8-9
FAEC Central FL News .....	12
FAEC Membership Application .....	14

## ADVERTISER INDEX

CED.....	12
FAEC Business Card Page.....	Inside Back Cover
Federated Insurance .....	10
Ferran Services & Contracting .....	4
GrayBar .....	13
H•D Supply.....	Back Cover
Mike Holt.....	11
Richard Watson .....	4
SESCO .....	Inside Front Cover

X  
E  
D  
N  
I

**FAEC**  
Magazine

FLORIDA ASSOCIATION OF  
ELECTRICAL CONTRACTORS  
PO BOX 180458, CASSELBERRY, FL 32718-0458  
407-260-1511 • FAX 407-260-5732



Published four times a year by



**President** • Troy T. Bausinger

**Publisher & Editor** • David Cane

**Assistant Art Director  
& Photographer** • Michelle Lala

**Advertising Director** • Brett Glaffelter

**TPI Custom Publishing**

24 Arnett Avenue, Suite 200 • Lambertville, NJ 08530

P. 609-397-5601 F. 609-397-5640

Copyright 2007 by TPI Custom Publishing.  
No reproduction without permission.

Cover Image: ©iStockphoto.com/Michael Braun



By Janice Ficarroto  
FAEC Executive VP

Spring is quickly approaching and registration has already begun for the Annual Spring Conference being held at the Omni Hotel at beautiful Champion's Gate here in Orlando. Event brochures have already been mailed and early indications are this will be another great event.

Your response to this year's dues billing has been overwhelming! Thank you so much for all your continued support and participation. Over 75% of our members paid their 2007 dues by February 1<sup>st</sup>—even with the dues increase. Our Board struggled this year with the decision to increase the dues slightly, but increasing costs forced our hand. In reviewing our records, we find the last dues increase was AT LEAST ten years ago! It seems all costs have risen except for our dues. Based on that premise, we felt the increase was needed in order to continue our level of service to the members. Hats off to you all for such outstanding support! Remember, this is YOUR association! In order to get anything out of it, you must participate.

If you haven't as yet reviewed the spring conference agenda, take a look! We've got a great line-up of both technical and business classes all approved for CE Credit. I've done something a bit different this

conference. I put in a "Let's Talk" networking session for Contractors-only moderated by our State President, Mike Caughen. So many times I've had members tell me that the most valuable information they obtain at the conferences is for just "networking" with fellow contractors. So, Katie bar the door and anything and everything is open for discussion—except pricing—in this session. Hope you can join us.



Image courtesy of the Omni Orlando Resort at ChampionsGate

In closing, I am once again asking for volunteers. FAEC has several committees we could use some help with. The Legislative Committee can always use help and so can the membership committee. Both these committees are the life-line of our organization. The "fun" committees—the auction committee and the special events committee—can also use some input; I chair both those committees and would love input for some new, fresh event ideas.

Please call me if you have an interest in serving on a committee and helping out. Again, I hope we see you this April at the Omni Hotel for the Spring Conference. Thank you all, once again, for being so wonderful!

## FAEC BENEFITS OF MEMBERSHIP INCLUDE:

- A Voice in the Legislative Process through a full-time lobbyist in Tallahassee.
- An Annual "Spring Conference" & "Fall Convention" offering Continuing Education classes relative to license renewal.
- The official publication of FAEC — The "Contractor" bringing you up-to-date on association information and industry news.
- A Group Major Medical Insurance Program.
- A General Liability Insurance Program.
- An Annual Membership Directory.
- "Legislative Alerts" distributed throughout the session to keep you abreast of industry concerns.
- The opportunity to interact with fellow contractors to share industry concerns and discuss industry issues.

Your Invitation  
to Membership  
In FAEC!

Join With An Elite Group...

**KENNETH CROSS**  
ELECTRICAL DIVISION MANAGER

www.ferran-services.com  
kcross@ferran-services.com

### FERRAN SERVICES & CONTRACTING

AIR CONDITIONING  
CAC 010842

ELECTRIC  
EC 0001804

PLUMBING  
CFC 050579

530 GRAND STREET  
ORLANDO, FL 32805-4795  
(407) 422-3551  
FAX # (407) 648-0961

4420 EASTPORT PARK WAY  
PORT ORANGE, FL 32127-6044  
(386) 322-6168  
FAX # (386) 322-2259

**RICHARD WATSON**  
GOVERNMENT AFFAIRS CONSULTANT

108 E. JEFFERSON ST., SUITE C.  
TALLAHASSEE, FL 32301  
TELEPHONE — 850-222-0000  
FAX — 850-222-0095  
RWATSN@AOL.COM

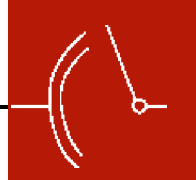

## Governor Crist Signs Comprehensive Insurance Bill

Governor Crist signed the far-reaching property insurance bill which was passed by the Legislature in Special Session on January 22<sup>nd</sup>. The Governor said, "Help is on the way! We have heard the calls for help from Floridians suffering from high insurance rates."

In my 25 years of lobbying in Tallahassee, I have never witnessed the amount of political pressure by the public which was brought upon the legislature for relief from spiraling increases in windstorm insurance. Both Democrat and Republican legislators felt the pressure. The bi-partisan cooperation was unprecedented. The final bill was passed unanimously in the Florida Senate and had only two dissenting votes in the Florida House of Representative.

### What Does The Bill Do?

The bill could lower premiums between 5% and 40%. Critics of the measure warn that the premium decreases are obtained by shifting the risk to taxpayers who would be assessed for deficits in the state-run Citizens Insurance when the next mega-storm hits. The bill does the following:

#### Lowers Rates

- Allows property owners to exclude windstorm coverage from their policies.
- Allows policyholders to exclude contents coverage.
- Removes the requirement that Citizens Property Insurance Corp charge the highest premiums in the state.
- Repeals Citizen's January 1, 2007 rate increase and freeze rates at the December 31, 2006 level.
- Eliminates the cap on deductibles so a homeowner can choose a deductible other than the standard 2%, 5% or 10% in current law. However, the policyholder must execute a written statement demonstrating understanding and intent, and must obtain approval by a lender if the deductible is more than 10% on a home valued under \$500,000.
- Allows non-homestead properties to be eligible for Citizens coverage effective March 1, 2007.
- Authorizes Citizens to write multi-peril policies in the wind storm pool, which will result in a direct decrease in premiums for at least 110,000 policyholders.

#### Protects Policyholders

- Requires all Florida-only insurance company subsidiaries to have a surplus of at least \$50 million in liquid assets to help ensure that policyholders receive payment when they need it.
- Requires insurance companies to evaluate the hurricane-security of a structure rather than the date of construction when determining risk and establishing premiums. Age of the home may not be used as the sole reason for rejection of coverage.
- Requires insurance companies to give at least 100 days written notice, or written notice by June 1, whichever is earlier, for any non-renewal, cancellation or termination of a

homeowners policy that would be effective between June 1 and Nov. 30.

- Requires insurance companies to expedite payment of claims following a storm. Insurers must pay or deny a property insurance claim within 90 days of notified of the claim with an exception for factors beyond the control of the insurer.
- Prohibits excess profits by property insurers.

#### Expands The Market

- Requires any insurance company that writes homeowners policies in other states and writes auto insurance in Florida to sell homeowners insurance in Florida effective Jan 1, 2008.
- Allows Citizens to write statewide commercial insurance policies and to determine policy limits and premiums.
- Allows Citizens to sell traditional homeowners policies to 350,000 customers who currently buy only windstorm coverage from Citizens.
- Enables insurance companies to purchase additional backup insurance from the state's Hurricane Catastrophe Fund at rates lower than on the private reinsurance market.
- Repeals a law that had called for insurers to pay extra into the fund to build up its reserves.
- Allows state regulators to waive a deposit requirement for foreign-based reinsurance companies to lure more world wide reinsurers to sell coverage to Florida companies.
- Expands the right of Citizens to impose assessments on other lines of insurance in the event of a deficit in Citizens.

#### Panhandle Exemption In Building Code Eliminated

- Requires the Florida Building Commission to adopt the wind-borne-debris protection requirements of the International Building Code (2006) and the International Residential Code (2006) within the wind-borne-debris region as defined by those codes.
- Requires local jurisdictions to immediately enforce these requirements pending adoption by the Commission.

### Conclusion

The Governor and the Legislature believe that this bill is a "first step" and additional reforms will be considered in the Regular Session which begins March 6, 2006. The expansion of Citizen's right to assess other lines of insurance for deficits causes concern. Citizen's now writes about a third of all the windstorm policies in Florida. Essentially all these policies are in the coastal areas. Since 70% of Florida residents live near the coast, some critics have argued that the expansion of the potential Citizens assessment shifts the risk to inland residents. If Florida has minimal storms in the next couple of years, this bill will probably deliver the reductions in premiums projected. In a way, the Legislature is "calling the bluff" of the insurance industry in its assertion that punitive regulation will cause more companies to abandon the Florida market. Desperate situations such as the skyrocketing insurance premiums call for bold action. As Governor Crist said, "With this legislation, the powerless have become the powerful, and the credit goes to the people of Florida for letting their voices be heard."

*Rick Watson*

*PO Box 10038, Tallahassee, FL 32302*

*(850) 222-0000, (850) 222-9059 (fax), (850) 591-4770 (cell)*

*rick@rwatsonandassociates.com (email)*

*www.rwatsonandassociates.com (website)*



# GROUNDING VERSUS BONDING

By Mike Holt, NEC Expert

## Part 4 [Based on the 2005 NEC]

### Grounding and Bonding of Separately Derived AC Systems

When you hear “separately derived systems (SDS), do you automatically think of generators? If you don’t work with generators, you may think SDS is not relevant to you. However, that thought may conflict with the reality of your situation.

Here’s a frequently overlooked fact: All transformers, except autotransformers, are separately derived. This is because the primary circuit conductors have no direct electrical connection to the secondary circuit conductors.

Here’s another frequently overlooked fact: Not all generators are separately derived. A generator supplying a transfer switch that opens the grounded neutral conductor or if there is no grounded neutral conductor is separately derived [250.20(D) FPN 1]. See Figure 1. But often generator setups don’t switch the grounded neutral conductor in the transfer switch.

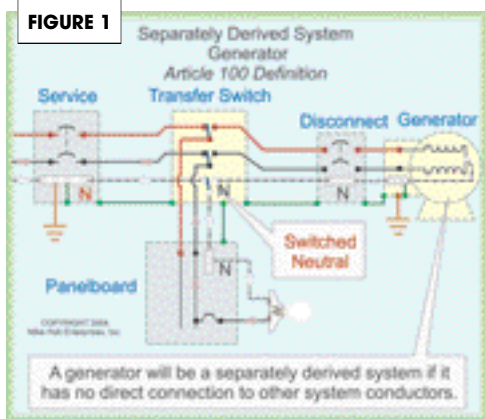

FIGURE 1

To determine if you have an SDS, start with the definition given in Article 100. An SDS is a premises wiring system whose power derives from a source other than a service. It also has no direct electrical connection (including a solidly grounded circuit conductor) to supply conductors originating from another system (Figure 2).

### System Bonding Jumper

In Part 3 of this series, we learned you can’t make neutral-to-case (load side) bonds [250.24

(A)(5)]. We also learned this rule provides an exception for SDS, if you follow the requirements of 250.30(A)(1).

Bonding the metal parts of the SDS to the secondary grounded neutral terminal—by installing a system bonding jumper—ensures quick removal of dangerous voltage from a secondary ground fault. Opening the overcurrent protection device of the secondary circuit [250.2(A)(3)] accomplishes this removal.

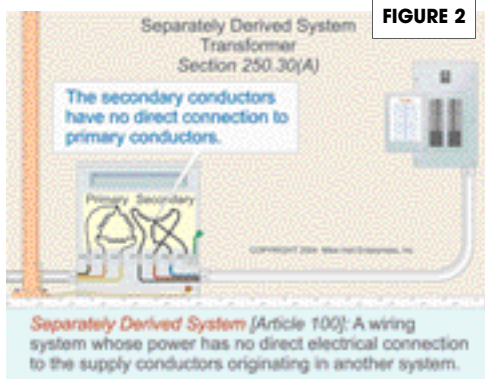

FIGURE 2

### System Bonding Jumper:

- Connects the equipment grounding conductors of the SDS (metal case) to the grounded neutral conductor (typically the X0 terminal).
- Connect the system bonding jumper, per 250.28(A) through (D), and size it based on the derived phase conductors.
- Install the system bonding jumper at only one location. Either at the source or the first system disconnecting means or over current device.

Dangerous objectionable current will flow on conductive metal parts of electrical equipment, metal piping, and structural steel—in violation of 250.6(A)—if you improperly install the system bonding jumper at both the SDS and the secondary system disconnecting means (Figure 3).

### Size Matters

Size the system bonding jumper per Table 250.66 based on the area of the largest

ungrounded secondary conductor [250.28(D)].

### Question:

What size system bonding jumper do you need for a 45 kVA transformer, where the secondary conductors are 3/0 AWG?

- (a) 4 AWG
- (b) 3 AWG
- (c) 2 AWG
- (d) 1 AWG

Answer: (a) 4 AWG (Table 250.66).

Where you run an equipment bonding jumper to the secondary system disconnecting means, size it per Table 250.66 based on the area of the largest ungrounded secondary conductor.

Question: What size secondary equipment bonding jumper do you need for a nonmetallic raceway containing 600 kcmil secondary conductors?

- (a) 1 AWG (b) 1/0 AWG
- (c) 2/0 AWG (d) 3/0 AWG

Answer: (b) 1/0 AWG (Table 250.66).

Where you run SDS conductors in parallel, install a secondary equipment bonding jumper in each raceway (or cable) and size it per Table 250.6 based on the area of the largest ungrounded secondary conductor [250.102(C)].

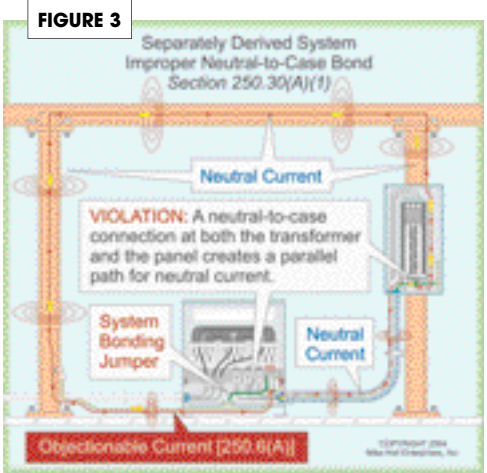
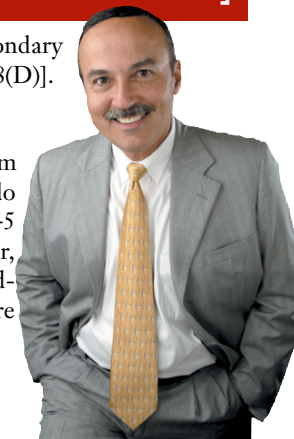

FIGURE 3





## Grounding Electrode Conductor (GEC)

For each SDS, ground the grounded neutral terminal (typically X0) to a suitable grounding (earthing) electrode of a type identified in 250.30(A)(7). Size the secondary system grounding (earthing) electrode conductor per 250.66 based on the total area of the largest ungrounded secondary conductor.

To prevent objectionable current flow in metal parts of electrical equipment, metal piping, and structural steel, terminate the GEC to the same point on the SDS where you installed the system bonding jumper.

Note the exceptions:

- Where the system bonding jumper [250.30(A)(1)] is a wire or busbar, you can terminate the GEC to the equipment grounding terminal bar or bus on the metal enclosure of the SDS (Figure 4).
- Where the SDS originates in listed equipment suitable as service equipment, you can use the GEC from the service or feeder equipment to the same grounding electrode as the GEC for the SDS—if it meets the size requirements.
- You do not need to ground (earth) SDS rated 1 kVA (1,000 VA) or less. But you must install a system bonding jumper per 250.30(A)(1), to ensure the clearing of ground-faults.

FIGURE 4

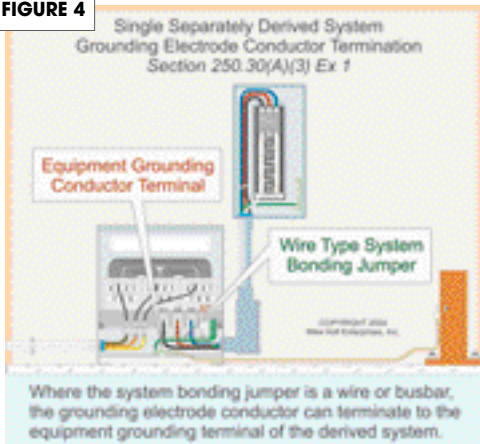

Connect grounding (earthing) electrode tap conductors to the GEC without splicing the common GEC. Install the GEC per 250.64—the basic requirements are that the GEC be:

- Copper, where within 18 in. of earth [250.64(A)].
- Securely fastened to the surface on which it's carried [250.64(B)].
- Adequately protected, if exposed to physical damage [250.64(B)].

If you run the GEC in metal enclosures, make them electrically continuous from the point of attachment to cabinets (or equipment) to the GEC [250.64(E)]. Bond building structural steel and all metal piping to an effective ground-fault current path, per 250.104(D).

If you have multiple SDS, you can ground the grounded neutral terminal (X0) of each SDS to a common GEC. But, the GEC and grounding (earthing) electrode tap must comply with 250.30(A)(4)(a) through (c) (Figure 5). We can summarize those as:

- Common GEC Size.** The common GEC must not be smaller than 3/0 AWG copper or 250 kcmil aluminum.
- Tap Conductor Size.** Size each grounding (earthing) electrode tap per 250.66 based on the largest separately derived ungrounded conductor of the SDS.
- Connections.** Make grounding (earthing) electrode tap connections at an accessible location with a listed connector or an exothermic weld. Another option: use listed connections to busbars not less than 1/4 x 2 in. If using aluminum busbars, comply with 250.64(A).

## Grounding (Earthing) Electrode

Terminate the GEC to a grounding (earthing) electrode as close as possible—and preferably in the same area as—the system bonding jumper. The grounding (earthing) electrode must be the nearest:

- Metal water pipe electrode, as specified in 250.52(A)(1), or
- Structural metal electrode, as specified in 250.52(A)(2)

If neither of these electrodes is available, use one of the following:

- Concrete-encased electrode encased by not less than 2 in. of concrete, located within (and near the bottom of) a concrete foundation (or footing) in direct contact with earth. This foundation must contain not less than 20 ft of electrically conductive steel reinforcing bars (or rods) not less than 1/2 in. in diameter [250.52(A)(3)].
- A ground ring encircling the building or structure, buried not less than 30 in. below grade. It must contain not less than 20 ft of bare copper conductor not smaller than 2 AWG [250.52(A)(4) and 250.53(F)].
- A ground rod having not less than 8 ft of contact with the soil [250.52(A)(5) and 250.53(G)].

- Other metal underground systems, piping systems, or underground tanks [250.52(A)(7)].

Observe the FPN in 250.30(7), to ensure quick removal of dangerous voltage from a ground fault. Bond metal water piping and structural steel in the area served by an SDS to the grounded neutral conductor at the SDS, per 250.104(D).

FIGURE 5

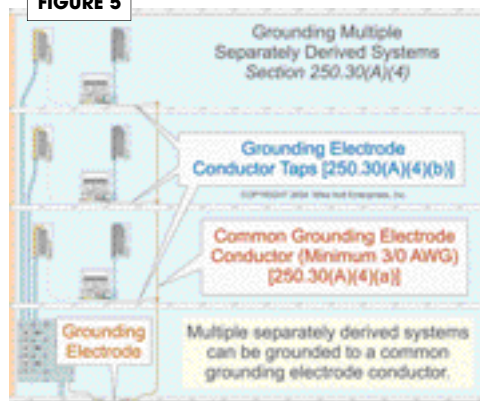

## Grounded Neutral Conductor

If you install the system bonding jumper at the secondary system disconnecting means instead of at the source of the SDS, follow these requirements this graphic omitted:

- **Routing and Sizing.** Route the grounded neutral conductor with the secondary conductors, and size it not smaller than specified in Table 250.66 based on the largest ungrounded conductor for the SDS.
- **Parallel Conductors.** If you install the secondary conductors in parallel, size the grounded neutral secondary conductor in each raceway or cable based on the area of the largest ungrounded secondary conductor in the raceway.

You cannot size the grounded neutral secondary conductor smaller than 1/0 AWG [310.4]. Remember, the grounded neutral conductor serves as the effective ground-fault current path.

Because SDS are pervasive, it's important to know—and correctly implement—SDS requirements. A mistake in the grounding and bonding of an SDS can prevent the clearing of a fault and it can allow dangerous potential to build on metal parts of the electrical system. Your new knowledge of SDS grounding and bonding requirements allows you to prevent both problems.



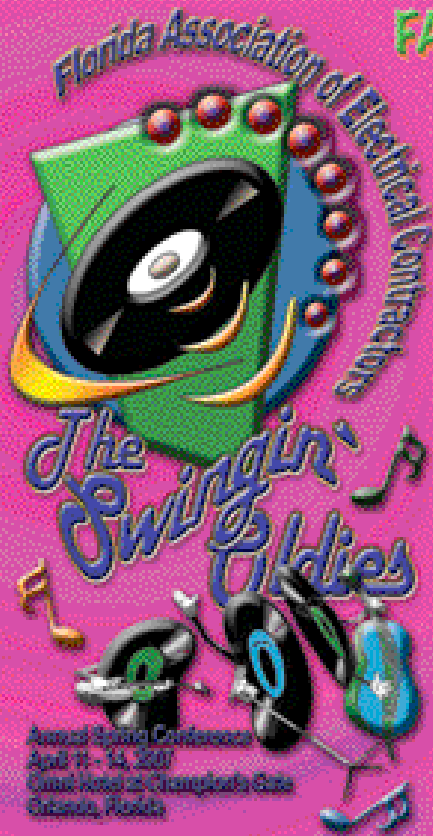

# FAEC SPRING CONFERENCE AGENDA THE OMNI HOTEL AT CHAMPION'S GATE, ORLANDO, FL.

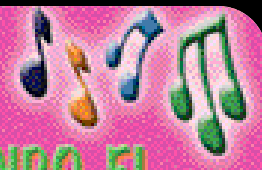

ECLB APPROVED SPONSOR #0000857

## Wednesday, April 11, 2007

**3:00-5:00 p.m. Registration & check in for early member arrivals.** Members can stop by and pick up their registration packages and familiarize themselves with the hotel.

## Thursday, April 12, 2007

**8:00-5:00 p.m. Member Registration & check in.** Members can stop by and pick up their registration packages anytime during the day.

**9:00-11:00 a.m. Committee Meetings** – An informal meeting of the various FAEC committees to discuss their activities including plans and goals for this year along with preparation of committee agendas for presentation at the 3:00 p.m. Board of Director's meeting.

**3:00-5:00 p.m. Spring Board of Directors Meeting.** This is the Spring meeting of the FAEC State Board of Directors. Open to all attending.

**5:00-On Open evening** for visiting area restaurants, shops or taking a shuttle over to one of the parks for dinner.

## Friday, April 13, 2007

**8:00-5:00 pm. Registration Desk Open** – Staff will be available to help with member check-in and questions.

**8:15-9:15 a.m. CLASS I** with Continental Breakfast – ECLB# 0000632 W "Worker's Compensation Update" -1 HR MANDATORY CE For License Renewal. Presented by Jeff Reed, Federated Insurance. Jeff will be on hand to review and discuss the 2007 worker's comp issues addressed during this year's session and cover insurance related issues in-depth.

**9:30-10:30 a.m. CLASS II** – ECLB #0007624 "Lighting & Life Safety" 1 HR CE T-Technical credit necessary for license renewal, presented by Allen Weiss, PE, LC, SESCO Lighting, Winter Park,

FL. This program will address the life safety requirements regarding egress emergency lighting and exit sign lighting for the State of Florida. Items to be covered include Florida Building Code, the Life Safety Code 101(2003) and the NFPA-National Electric Code (2005).

**10:45-11:45 a.m. CLASS II** – ECLB #0007632: "Sustainable Lighting Design" -1 HR-Technical (T) CE Necessary for License Renewal. Presented by Allen Weiss, PE,LC, SESCO Lighting, Winter Park, FL. This program will cover the meaning of light pollution light trespass, sky glow and glare, ways to control light pollution, sky glow and glare in outdoor lighting applications with an emphasis on Illuminating Engineering Society cut-off classifications. Also, design issues surrounding and the existing and proposed legislation controlling the lighting of Sea Turtle areas in the State of Florida concluding with the lighting design and submission requirements of LEED credit 8 (sustainable site).

**10:30-10:45 a.m. Refreshment Break** – Time for a quick "pick me up" with fresh juice, coffee and granola bars.

**9:30-12:00 Noon Spouse Class** – A special event for our spouses to keep them entertained while contractors are busy with classes.

**12:00-1:00 CLASS III** – ECLB #0000786: "Work Place Safety" - 1 HR-Safety (S), CE Necessary for License Renewal. Presented by Jeff Reed, Federated Insurance. An update on OSHA Safety Regulations and Standards as to how they relate to the electrical contracting industry. Lunch will be served for all attendees

**1:30-3:30 CLASS IV** – ECLB# Pending Approval: 2 HRS CE- Technical (T) "2007 NEC Code Update," presented by Mike Freiner, Brite Future Electric, Ocoee, FL. Mike's presentation will include a complete update on the changes in the 2007 National Electrical Code as compared to the previous code. Chapter's 1 through 5 will be covered with emphasis on Article 110, 210, 250, 300, 312, 314, 330, 356, 366 and 590. An important update you won't want to miss.

**3:30-5:00 "LET'S TALK"-A contractors networking session.** An open, informal "round-table" session for candid contractor discussion including issues such as labor, material supplies, trends in the industry, licensing, apprenticeship training, wages, etc. You are free to bring forth any issue you would like to discuss with fellow contractors. THIS SESSION IS LIMITED TO CONTRACTOR OWNERS ONLY. Moderator, Mike Cauthen, FAEC President and Legislative Chairman.

**6:30-9:30 p.m. Theme Party Dinner and Entertainment** – A fun-filled Sock Hop event complete with Hooola Hoop Contest, Twist Contest, Bubble Gum Blowing Contest, dancing, and the silent auction to help raise funds for our 2008 Legislative activities. Come prepared to

laugh a bunch, enjoy a great evening of socializing and take home some great prizes! Also prizes will be awarded for the best dressed 50's Couple. Auction Items gladly accepted.

## Saturday, April 14th, 2007

**8:00-9:30 a.m. Sunrise Breakfast Buffet and Mini-Mart Networking Session.** Start the day off right with a full breakfast buffet and another session of networking with our Association benefit provider companies. Due to the success of the last event, this program will be repeated and networking partners have increased. Space is limited – Register early for Great Door Prize Give-aways and a grand prize drawing of \$250.00

**9:30-11:30 SPOUSE EVENT** – A shopping trip is planned for the local boutiques of the area with ample time to visit the specialty shops surrounding the Champion's Gate Village.

**9:45-12:00 CLASS V** – ECLB # Pending Approval "Generation Y-Understanding, Managing and Motivating the New Work Force" – 2 HRS CE Business (B) Necessary for License Renewal. Presented by Mike Freiner, Brite Future Electric, Ocoee, FL. Mike will present a variety of issues during this program including recruiting, training, managing, recognizing and rewarding our Generation "Y" employees. He'll also focus in on our U.S. Department of Labor statistics regarding our construction workforce including employment projections, an over-view of apprenticeship training, the industry's growth potential until 2012 and many other pertinent issues. This is an excellent program all employers should attend – it will enlighten you greatly on tomorrow's workforce!

**12:00-1:00 pm Lunch for All Attendees** – Sit, relax and visit with fellow contractors.

**1:30-3:30 CLASS VI** – ECLB # Pending Approval "Grounding of Transformers and Compliance with NEC 700-27 and 701.18- Selectivity" –2 HRS CE Technical (T) Necessary for License Renewal. Presented by Jeff Small, Specification Engineer, General Electric, Florida. During the grounding section of this program, Jeff will review NEC Article 250 including definitions, safety considerations, system bonding jumpers, general requirements, effective ground fault current paths, grounding and bonding and NEC 2005 Code changes in Article 250.

**3:30-On Free time** to visit the area or relax by the beautiful Pool and float down the "Lazy River".

*In accordance with the American with Disabilities Act, those individuals requiring special accommodations or equipment during the meeting should contact headquarters well in advance of the meeting at 407-260-1511.*



# Registration!!!

## ANNOUNCING FAEC 2007 ANNUAL SPRING CONFERENCE OMNI CHAMPIONS GATE, ORLANDO, FLORIDA

APRIL 12-14, 2007

### REGISTRATION FORM

#### INSTRUCTIONS:

1. Complete all portions of this form and return to FAEC, P.O. Box 180458, Casselberry, FL 32718-0458. A check payable to FAEC must accompany this form in order to secure registration.
2. Your name and company will appear on your name badge and registration materials as you indicate below.
3. Type all portions of this form.

Conference Registration: Includes all educational classes, CE Certificates, seminar hand-outs and meal functions.

NAME: \_\_\_\_\_ NICKNAME: \_\_\_\_\_

YOUR STATE LICENSE NUMBER: \_\_\_\_\_

SPOUSE/GUEST: \_\_\_\_\_ NICKNAME: \_\_\_\_\_

COMPANY NAME: \_\_\_\_\_

ADDRESS: \_\_\_\_\_

CITY: \_\_\_\_\_ STATE: \_\_\_\_\_ ZIP: \_\_\_\_\_

PHONE: \_\_\_\_\_

#### REGISTRATION FEES:

Full Registration Fee must accompany this form. Full refund given if cancellation is received 14 days prior to convention.

#### After March 1, 2007

- \_\_\_\_\_ FAEC Member(s) @ \$350.00 per person
- \_\_\_\_\_ Project Manager/Key Personnel \$250.00 per person
- \_\_\_\_\_ Member Spouse/Guest(s) @ \$225.00
- \_\_\_\_\_ Non-Member \$500.00 per person\*\*

**PLEASE MAKE ALL HOTEL ACCOMMODATIONS DIRECTLY WITH THE OMNI CHAMPIONS GATE,  
407-390-6664 ... ALL ROOMS BLOCKED FOR FAEC WILL BE RELEASED AT THAT TIME!**

Room Rate: Single/Double \$169/Per Night.

\*For early arrivals/stayovers, the group rate will be honored to all attendees with no minimum/maximum required, subject to availability.

\*\* If non-member joins FAEC within 30 days of conference \$150.00 will be applied towards first years dues.

\*\*\*PLEASE NOTE THAT A CREDIT CARD AUTHORIZATION MUST BE USED TO SECURE ALL ROOMS!

PLEASE MAKE A COPY FOR YOUR RECORDS

REGISTRATION DEADLINE: April 1, 2007

RETURN TO: FAEC, P.O. BOX 180458, CASSELBERRY, FL 32718-0458  
(407) 268-1511- FAX 407-268-5732

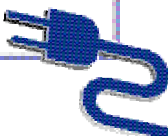

# If a Business fails to check the Motor Vehicle Record of a driver,

someone may have to pick up the pieces.

Ask your local Federated representative about how your business can implement a **DRIVER INSURABILITY PROGRAM**, which includes systematic procedures for checking MVRs—because your business is only as safe as your drivers.

Nationwide coverage, local service.

The FEDERATED Insurance Companies  
Home Office: 121 East Park Square, Owatonna, Minnesota 55060  
(507) 455-5200 • INTERNET: [www.federatedinsurance.com](http://www.federatedinsurance.com)

\* All programs and services may not be available in all states.



# www.MikeHolt.com

## Your **FREE** Electrical Internet Resource



MikeHolt.com is internationally recognized as the number one Electrical Code Website and Code Forum in the world, and for good reason.

It's a great site packed full of the most up-to-date technical electrical information you'll need, as well as great electrical graphics, video clips, online training, electrical calculators and so much more, and it's absolutely FREE!

### **Ask yourself the following questions:**

- **Do you have a technical question?**
- **Want to take a Code quiz and test yourself?**
- **Want to stay current with the electrical industry via a daily newsletter?**
- **Would you like some graphics or video clips for a PowerPoint presentation?**
- **How about software for electrical calculation?**
- **Any need for online training?**
- **Do you like FREE stuff?**

**If you answered yes to any of the above questions, then you must visit [www.MikeHolt.com](http://www.MikeHolt.com) to take advantage of the many technical resources that are available to you for FREE.**



*"As for me and my house, we will serve the Lord [Joshua 24:15]"*

**Mike Holt Enterprises, Inc. • 1.888.NEC.CODE • 10320 NW 53rd St., Sunrise, FL 33351**

## President's Message

By Mike Freiner, Bright Future Electric, FAEC/CF President

### Happy New Year to All!

Here we go again, another year gone and another before us. Along with the New Year comes new challenges and opportunities. I had so much fun working with the many fine members of the FAEC/CF chapter last year; I accepted the position of President one more time.

As you all know 2006 was a "do or die year for us". Fortunately we proved the theory that "perseverance and hard work breeds success". I am proud to announce that we are once again on solid ground and we are ready to take our organization to the next level. None of this could have been possible without the support of our members and the outstanding performance of our Board of Directors. I feel honored to have

the opportunity to work with them again this year.

Our committees are already off and running and you as members can look forward to some outstanding educational programs, legislative updates, networking opportunities, industry best practices and let's not forget the fun times at our many recreational events.

Oh, by the way, we can always use more help. If you would like to assist on one of our committees please contact Cheryl at the FAEC/CF Office and she will be happy to assist you. (407-260-1511)

I will close with the following thought. *The most valuable gift you can give someone is the gift of your knowledge.*

Wishing you all a great and prosperous New Year!

## FAEC/CF 2007 Calendar of Events

MAR 22	Lunch Meeting - Code Update Panel
MAR 28	Educational Program - Joe Bell - Basic Blue Print Reading
MAR 31	FAEC/CF Bass Tournament - Lake Toho
APR 5	Board of Directors Meeting   11:30am, Association Headquarters
APR 11-14	FAEC State Spring Conference - Champions Gate
MAY 3	Board of Directors Meeting -   11:30am, Association Headquarters
JUNE 7	Board of Directors Meeting -   11:30am, Association Headquarters
JUNE 15	Annual BBQ
JUNE 1	Golf Tournament
SUMMER TBA	Educational Program - Joe Bell - Job Foreman
JULY 12	Board of Directors Meeting -   11:30am, Association Headquarters
AUG 2	Board of Directors Meeting -   11:30am, Association Headquarters
AUG TBA	Educational Program - Joe Bell - Estimating
SEPT	Board of Directors Meeting -   11:30am, Association Headquarters
SEPT 2	Casino Night - Hilton Altamonte Springs
OCT 11	Board of Directors Meeting -   11:30am, Association Headquarters
OCT 24-28	FAEC State Annual Convention - Riverwalk, Jacksonville
NOV 1	Board of Directors Meeting -   11:30am, Association Headquarters
NOV TBA	Table Top Expo
DEC 6	Board of Directors Meeting -   11:30am, Association Headquarters

### Nationwide Support-Local Service



Consolidated Electrical Distributors

## FAEC/CF Community Service Committee Report

Through your participation, our association was able to give a \$2,000 check to Camp Challenge for the renovation of their dining hall. I met with Julie Nassar (Director of Development) and John Hazelton (Camp Administrator) for a tour of the facilities. The camp is getting very close to reaching their goal and hopes to get started soon. Our contribution was appreciated and we should get mentioned in their quarterly publication (Changing Lives).

Our three successful fundraisers—thanks to all—were raffles for a bucket of cheer at State Convention, \$200 Bass Pro Shop gift certificate at the annual Bar-B-Q and volleyball tournament, and a mystery gift box at our casino night. It was fun raising the money for a good cause.

The Board of Directors has expressed a desire to continue fundraising this year and designating the money to Camp Challenge. Camp Challenge is Florida's only Easter Seal camp and is designed especially for children and adults with physical disabilities.

May the year 2007 bring blessings to all with the gratification of helping others.

Sincerely,

Dave Morris, Committee Service Chairman

## Unscheduled Absence Survey

What does it cost you when some of your employees don't come to work? According to a CCH survey, unscheduled absences are at their highest since 1999. Between 60% and 70% of those absent are missing due to reasons other than personal illness.

If you would like to see more information from this survey, it is available for \$40 from [www.hr.cch.com](http://www.hr.cch.com). You can also read about it in Workforce Central Florida's January 19th newsletter. [www.enebuilder.net/wcf/](http://www.enebuilder.net/wcf/).

## NEC Through the Years (or What I Learned from My Inspector)

By Jamie Fugate, FEAT Program Director

In the last four FAEC newsletters, you have read how the National Electrical Code has changed over the years. This article was going to be similar – how has the NEC changed over the last 100 years?

In the 1907 NEC, the second paragraph of a page titled “General Suggestions” says, “In all ways, special attention must be paid to the mechanical execution of the work. Careful and neat running, connecting, soldering, taping of conductors and securing and attaching of fittings, are especially conducive to security and efficiency, and will be strongly insisted on.”

Fast forward 100 years to our newly-adopted 2005 NEC: “110.12 Mechanical Execution of Work. Electrical equipment shall be installed in a neat and workmanlike manner.” Instead of researching all the intervening codes to see how that section had evolved, I got caught up in memories...

The first time an inspector ever cited that code in my personal experi-

ence was in Seminole County. An electrician in our company used surface-mounted EMT in an exposed location about 16 feet above the floor in a large warehouse. He did not use box offsets and used 1-hole straps installed just a few inches from the boxes. It was memorable for me, because I was the one who was told to fix the problem!

The second time, in the City of Orlando when trimming out, my helper left 8 – 10 inches of romex in each box and only stripped 3" of the jacket.

On the Internet, an electrician posed the question: “If the purpose of the NEC is the practical safeguarding of persons and property, why do they care if it’s installed in a workmanlike manner?” That’s an interesting question... Could it be one of those “catchall” code sections that cover a multitude of elsewhere undefined problems?

When was the first (or last) time an inspector taught you something about the code?

## ■ ■ DON'T MISS!!! ■ ■

### FAEC/CF Bass Tournament

Saturday, March 31, 2007  
Safe Light till 2:00pm  
West Lake Toho at  
Southport

Entry Fee: \$40.00  
Prizes for 1<sup>st</sup> through  
3<sup>rd</sup> Place  
Lunch served after the  
tournament  
Door Prizes!

Please have the entry fee  
and form in to FAEC/CF  
by March 23, 2007 so we  
can make accommodations  
for lunch. All boats will be  
sent out by the order in  
which applications are  
received.

**SO HURRY...A BIG BASS  
POT** will be collected on  
site prior to launch for all  
interested. Big Bass Pot  
Winner Take ALL!!!

### Basic Blue Print Reading

Wednesday, March 28, 2007  
6:00pm - 8:00pm

Attendees will be  
instructed on:

- Finding the “Red Flag” items on plans and specifications
- Understanding the lighting and panel schedules
- Reviewing the electrical, mechanical, architectural and civil drawings
- Understanding symbols, power notes and plans notes
- Preparing plans for estimating

\*\*Space is Limited to 18 Students

Mid Florida Tech  
Building 1600, Room 017  
2900 West Oak Ridge Road,  
Orlando  
Members Only: \$35.00pp  
Non-Members \$75.00pp

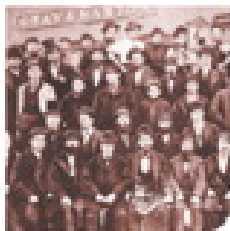
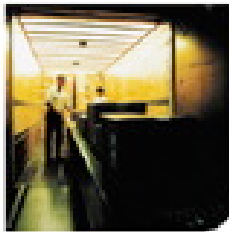
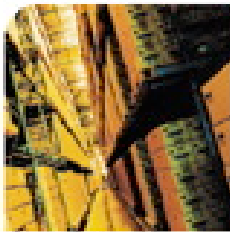

**GraybaR.**  
works to your advantage

Our employee-owners work together with shared interests and a common mission: To be the vital link in the supply chain, adding value with efficient and cost-effective service and solutions for our customers and suppliers. When you partner with us, we can help you streamline your processes, reduce your inventory levels and consolidate your buying efforts to meet your long-term purchasing objectives.

That's Graybar teamwork, and that works to your advantage.

LEARN MORE ABOUT HOW GRAYBAR WORKS TO YOUR ADVANTAGE AT [WWW.GRAYBAR.COM](http://WWW.GRAYBAR.COM) OR CALL 1-800-GRAYBAR.

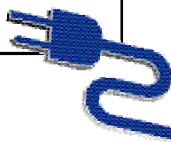

# Florida Association of Electrical Contractors

## Application for Membership

COMPLETE AND MAIL TO FAEC • PO BOX 180458 • CASSELBERRY, FL 32718-0458

**With your Check for the proper dues amount!**

Full year's dues must accompany application. Dues for second year will be prorated on applications received March 1 thru November 1.

I, \_\_\_\_\_, apply for membership in FAEC...a non-profit organization, devoted to the betterment of the Electrical Contracting Industry in the State of Florida.

Name: \_\_\_\_\_ Title: \_\_\_\_\_

Company: \_\_\_\_\_ Phone (\_\_\_\_) \_\_\_\_\_

Address: \_\_\_\_\_ Fax: (\_\_\_\_) \_\_\_\_\_

\_\_\_\_\_

City St. Zip County

### CONTRACTOR

*(open to all state registered or certified electrical contractors)*

**Dues Schedule (Check One):**

**New Member First Year Only, \$150**

**State Certified or Registered Electrical Contractor: \$300.00 Per Year**

**Certified Specialty Contractor:**  
licensed by ECLB \$200.00 Per Year

**Key Personnel:** Any person (non-master) in the employ of an electrical contractor desiring to support the interests and efforts of the Association whose responsibilities include overseeing construction projects, estimating, purchasing, safety programming, etc. \$50.00 Per Year

**Non-Contractor:** A master electrician not conducting electrical contracting \$50.00 Per Year

Company Contact Name: \_\_\_\_\_

ER or EC Number: \_\_\_\_\_

### AFFILIATE

*(open to all manufacturers, distributors, suppliers, and others who wish to maintain close contact with the industry and support the goals of the association)*

**New Member First Year Only, \$150**

**Dues Schedule: \$300.00 Per Year**

In 25 words or less describe what your firm sells to electrical contracting firms, or describe your interest in relation to FAEC.

\_\_\_\_\_

\_\_\_\_\_

\_\_\_\_\_

\_\_\_\_\_

**I agree to assist, to the best of my ability, the efforts of FAEC to improve our industry and abide by the by-laws and code of ethics.**

Signed: \_\_\_\_\_ Date: \_\_\_\_\_

Sponsored by: \_\_\_\_\_

Current FAEC Member

**Contractor Applicants ONLY!** Please list 3 electrical material supplier references with whom you've done business with in the last 12 months.

- |    |                        |                      |
|----|------------------------|----------------------|
|    | <small>Company</small> | <small>Phone</small> |
| 1) | _____                  | _____                |
| 2) | _____                  | _____                |
| 3) | _____                  | _____                |

**The ECLB (Electrical Contractors Licensing Board) Will be contacted for pending violations against your license...Please be sure the number you are supplying is absolutely correct!**





**Amber Electric, Inc.**  
Commercial • Residential • 24-Hour Service

P.O. Box 737 • 630 Kissimmee Avenue  
Ocoee, FL 34761-0737

Main Telephone: 407.656.2335  
General Fax: 407.656.1673  
Estimating Fax: 407.905.0133  
Purchasing Fax: 407.656.4978  
Commercial Fax: 407.656.9375  
Human Resource Fax: 407.656.1568



FL Lic. #EC0000700



**Installation & Service**  
**Commercial - Residential**  
Sate Cerified EC0001196

**WILLIAM L. MANNING**

10876 S.W. 91st Avenue  
Ocala, Florida 34481

(352) 854-8338 Fax (352) 854-4009



Wiring Florida since 1958

430 West Drive • Altamonte Springs, FL 32714  
P: (407) 788-3500 F: (407) 682-1096  
C: (407) 402-1663

**ROCKY SNEED**  
Systems Department Manager  
E: rocky.sneed@tcelectric.com

ABC ACCREDITED QUALITY CONTRACTOR

EC0000981

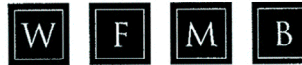

WRIGHT, FULFORD, MOORHEAD & BROWN  
ATTORNEYS

TIMOTHY R. MOORHEAD / tmoorhead@wfmblaw.com

WRIGHT, FULFORD, MOORHEAD & BROWN, P.A.  
145 NORTH MAGNOLIA AVENUE / ORLANDO, FL 32801  
407 425 0234 PHONE / 407 425 0260 FAX / www.wfmblaw.com



P.O. Box 20029  
4955 Swamp Fox Road  
Tallahassee, FL 32316

A FULL SERVICE COMPANY SINCE 1970

EC0001562



EC0001018

600 N. THACKER AVENUE . SUITE "A" . KISSIMMEE, FLORIDA 34741

407 752-9944 MELBOURNE  
407 846-4262 KISSIMMEE  
407 239-0260 ORLANDO  
904 589-1644 EUSTIS  
407 846-1136 FAX

COMMERCIAL  
INDUSTRIAL  
RESIDENTIAL  
SUBSTATION  
POWERLINE  
SERVICE

Coastal Electric Co. of Florida  
Jeff Sanders  
2759 St. Johns Bluff Road  
Jacksonville, FL 32246  
(904) 645-0026



R.N. "Bobby" Parker III  
General Manager / Senior V.P.

875 Jackson Avenue • Winter Park, Florida 32789  
407-646-8700 Ext. 774 • 407-647-8951 FAX  
State License #EC1858

C-7037 ER 0007827 RF 0049903



Well Drilling • Electric • Plumbing

MIKE CAUTHEN P.O. Box 473  
President 352/620-9322 Sparr, FL 32192

Phone 757-8424  
Fax 757-7811

EC 864  
EN 210908

**DeBERRY ELECTRIC Co., Inc.**  
Commercial • Industrial

David Alan DeBerry  
President

P.O. Box 26037  
Jacksonville, FL 32226-6037





**HUGHES** is now



**Bradenton**  
941.753.5602

**Holly Hill**  
386.255.7008

**Marianna**  
850.526.3271

**Panama City Beach**  
850.236.3419

**Tallahassee**  
850.575.0138

**Fort Myers**  
239.931.4400

**Jacksonville**  
904.783.4567

**Melbourne**  
321.724.5880

**Perry**  
850.838.3400

**Tampa**  
813.621.9649

**Fort Pierce**  
772.464.1590

**Kissimmee**  
407.870.8558

**Naples**  
239.643.1044

**Pompano Beach**  
954.782.6712

**Tavares**  
352.343.8118

**Fort Walton Beach**  
850.244.2566

**Lady Lake**  
352.753.4555

**Ocala**  
352.732.2995

**Port Richey**  
727.847.1170

**Venice**  
941.485.4861

**Gainesville**  
352.377.0792

**Lake City**  
386.719.9860

**Orange City**  
386.775.8222

**Sarasota**  
941.955.4701

**West Palm Beach**  
561.684.7466

**Groveland**  
352.429.2977

**Lakeland**  
863.688.5511

**Orlando**  
407.841.4710

**Sebring**  
863.655.2411

**Winter Haven**  
863.294.8000

**ALWAYS ON THE JOB.**

